



Each year, Norwegian and international oil companies invest significant resources safeguarding personnel and equipment against the danger of fire and explosion. Fireproofing is an important and comprehensive priority area. The disastrous Piper Alpha incident is an unfortunate example of a potentially devastating outcome when steel constructions are not well-protected against heat, fire, and explosion.

## **Epoxy Fire Protection Valve and Flange Box, Patented**

- Consists of few parts, which improves durability
- A product of the well proven Benarx F-epoxy - series
- Extremely robust, remarkably durable with a very low Life Cycle Cost (LCC).
- Jet and hydrocarbon fire-rated, tested and certified up to two hours.
- High-performance product, tested for explosion, age, and static electric discharge.
- Withstands extreme arctic climates.
- Non-absorbent with outstanding corrosion protection.
- Approved and used by global leaders in oil and gas (BP, Statoil, ConocoPhillips, Petro Canada, Shell).

## Product Overview

Removable fire insulation epoxy boxes are entirely covered with an expanding epoxy coating. In case of fire, the epoxy mass expands, creating a tight barrier between the fire area and the protected object.

The box can be mounted both on existing and new flange assemblies. Compared to alternatives, the box has an extremely compact construction and is made of few parts, making mounting and inspection easier. The boxes can be fitted with Benarx' patented drain plug for even better corrosion protection

**DURABLE** Removable fire insulation boxes are proven durable at the construction stage and in harsh offshore environments. They also offer protection against corrosion.

**SIMPLE & EFFICIENT INSTALLATION** Boxes are quickly and easily mounted and dismantled for repeated inspection, maintenance, and cleaning. We have a worldwide network of well- trained and equipped Qualified Producers.

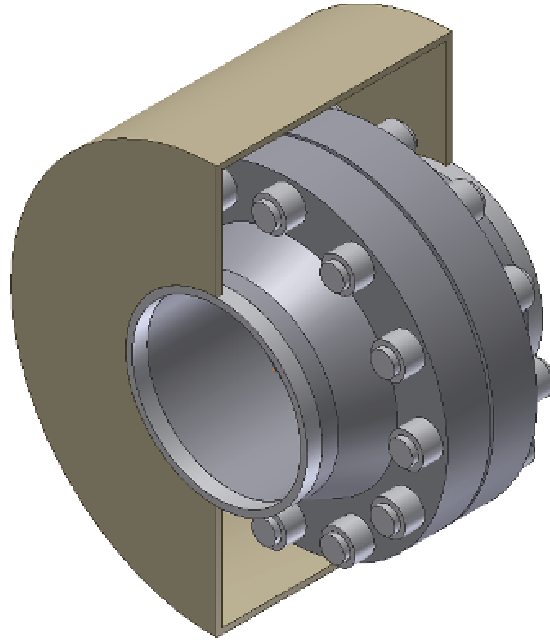

## Fire Protection Epoxy Box Flange Performance

PROPERTY	VALUE	METHOD
Maintain stability and integrity of equipment in a jet fire resulting from a high-pressure release of natural gas.	0 to 120 minutes.	Jet fire-tested OTI 95634
Safeguard stability and integrity of equipment at hydrocarbon fire temperatures.	0 to 120 minutes Hydrocarbon fire exposure curved.	Hydrocarbon fire exposure curved presented in EN 1363-2 Fire Resistance.
Ability to save working properties after explosion.	1.2 bar.	Gas explosion test.
Cycle-tested under various weather conditions reveal no change to product.	4200 hours (15 years' work life).	Age-tested according to NORSOK M 501, Rev.5 and ISO 20340:2003 E.
Usable in a hazardous environment for all gas groups.	No discharge.	Static electric discharge tested according to EN 13463-1 Annex C.

